

N°	Cod.	Descrizione	Description	Note	Qty	Model
1	0402 0342	Coperchio	Lid	Grigio / Grey	1	
2	2416 0309	Protezione Camino	Boiler Protection		1	
3	0477 0258	Carenatura Superiore	Upper Cover	11-15 litri / liters Grigio / Grey	1	6.15 - 8.15
	0477 0259	Carenatura Superiore	Upper Cover	18-21 litri / liters Grigio / Grey	1	9.18 - 9.21 10.18 - 10.21
4	0402 0341	Tappo	Cap		1	
5	1407 0051	Vite Speciali Carenatura	Special Cover Screw		2	
		Carenatura Principale	Main Cover	Grigio / Grey	1	
6	0477 0257	Carenatura Principale	Main Cover	Grigio / Grey	1	
7	3606 0022	Pomello Carenatura	Locking Cover Knob		2	
8	1407 0051	Vite Speciali Carenatura	Special Cover Screw		1	
9	0402 0343	Coperchio Filtro Acqua	Water Filter Lid		1	
10	0477 0256	Carenatura Inferiore	Lower Cover	Grigio / Grey	1	
11	3623 0038	Vite Speciale	Special Screw	M5x12	4	
12	2815 0026	Rivetto	Rivet	M5x13	1	
13	3002 0665	Staffa Supporto Carena	Cover Bracket		1	
14	0604 0102	Dado	Nut	M6	2	
15	2807 0024	Rondella	Washer	Ø6,4x11	2	
16	0604 0158	Dado	Nut	M8	2	
17	2811 0026	Rondella	Washer	Ø8,4x24x2	2	
18	2811 0030	Rondella	Washer	Ø6,4x12,5x1,6	2	
19	0604 0011	Dado	Nut	M6	2	
20	2434 0021	Pressacavo	Cable Holder	Ø15	1	
21	2807 0024	Rondella	Washer	Ø6,4x11	2	
22	3607 0244	Vite	Screw	M6x12	2	
23	0604 0158	Dado	Nut	M8	3	
24	2819 0028	Rondella	Washer	M8	3	

N°	Cod.	Descrizione	Description	Note	Qty	Model
25	2810 0083	Ruota	Wheel	Ø140	1	
26	2819 0028	Rondella	Washer	M8	3	
27	3607 0242	Vite Testa Esagonale	Hexagonal Screw	M8x16	3	
28	0402 0350	Copri ruota	Wheel Cover	Grigio / Grey	2	
	0402 0346	Copri ruota	Wheel Cover	Azzurro / Cyan	2	
29	0009 0179	Anello	Ring	Ø20	2	
30	2810 0082	Ruota	Wheel	Ø300	2	
31	3206 0233	Telaio	Frame		1	
32	2819 0029	Rondella	Washer	M10	1	
33	0604 0097	Dado	Nut	M10	1	
34	3607 0014	Vite Testa Esagonale	Hexagonal Screw	M10x120	1	
35	3607 0202	Vite Testa Esagonale	Hexagonal Screw	M10x12	1	
36	2811 0050	Rondella	Washer	Ø10,5x18x2	1	
37	2819 0029	Rondella	Washer	M10	1	
38	0017 0017	Assale Ruota	Wheel Axle	Ø20 L=776	1	
39	3605 0071	Vite Speciale	Special Screw		2	
40	1803 0103	Bull Bar	Bull Bar		1	
41	2807 0024	Rondella	Washer	Ø6,4x11	2	
42	0604 0102	Dado	Nut	M6	2	
43	2815 0026	Rivetto	Rivet	M5x13	1	
44	2807 0024	Rondella	Washer	Ø6,4x11	2	
45	3607 0161	Vite	Screw	M6x25	2	
46	3002 0651	Staffa Rubinetto Detergente	Detergent Tap Bracket		1	
47	2434 0044	Pressacavo	Holder	Ø31x38xSP.10	2	
48	0604 0158	Dado	Nut	M8	2	
49	2819 0028	Rondella	Washer	M8	2	

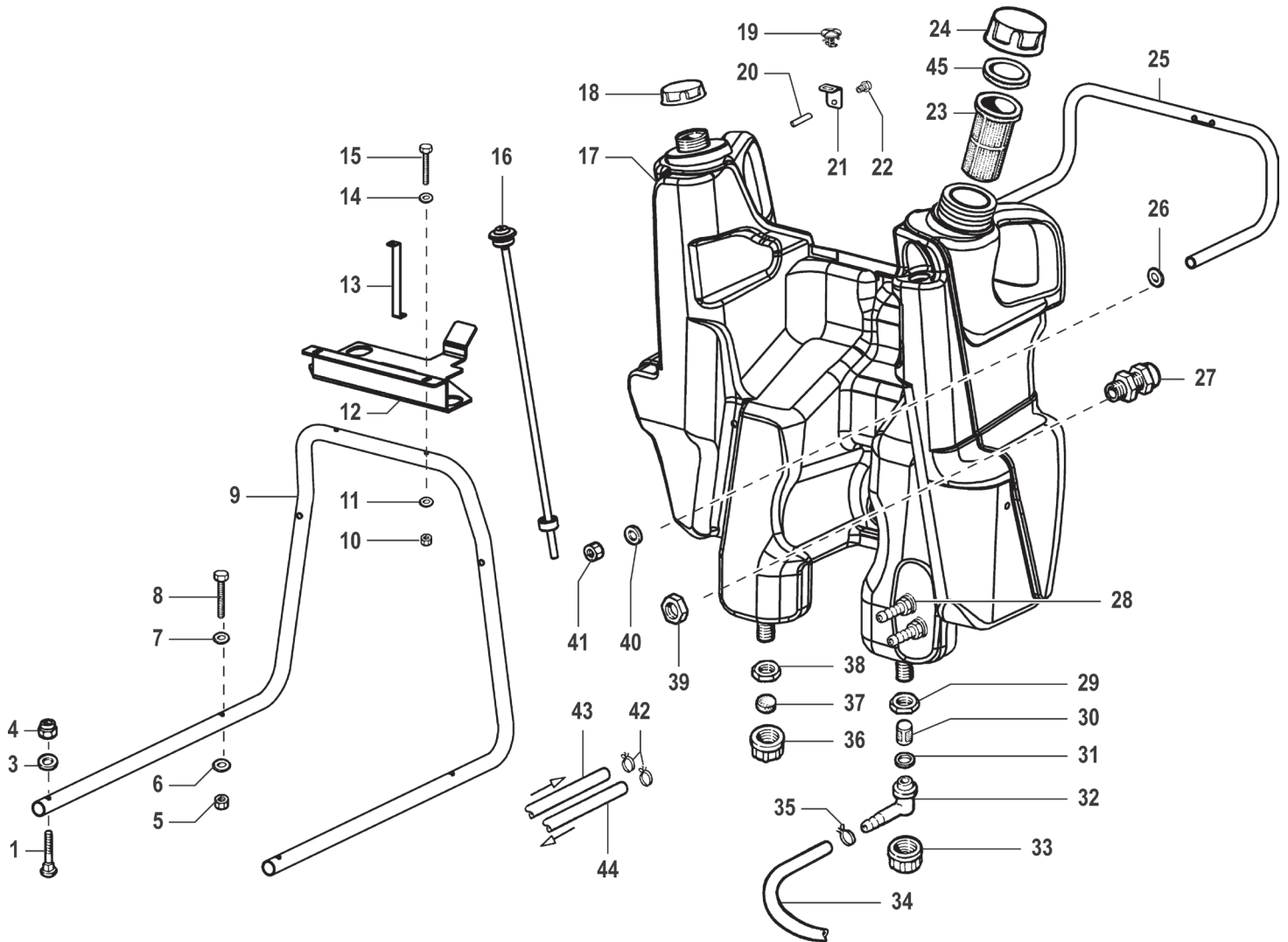

N°	Cod.	Descrizione	Description	Note	Qty	Model
1	3605 0071	Vite Speciale	Special Screw	M8x40	2	
3	2819 0028	Rondella	Washer	M8	4	
4	0604 0158	Dado	Nut	M8	2	
5	0604 0063	Dado	Nut	M8	2	
6	2811 0026	Rondella	Washer	Ø8,4x24x2	2	
7	2819 0028	Rondella	Washer	M8	2	
8	3607 0222	Vite	Screw	M8	2	
9	1803 0101	Manubrio	Handlebar		1	
10	0604 0102	Dado	Nut	M6	2	
11	2807 0024	Rosetta Elastica	Spring Washer	Ø6,4x11x2	2	
12	3002 0650	Staffa Quadro Elettrico	Electrical Panel Braket		1	
13	3002 0542	Supporto	Support		1	6.15 - 8.15
	3002 0677	Supporto	Support		1	9.18 - 9.21 10.18 - 10.21
14	2807 0024	Rosetta Elastica	Spring Washer	Ø6,4x11x2	2	
15	3607 0157	Vite	Screw	M6x40	2	
16	3042 0018	Kit Livello Gasolio	Fuel Level Sensor Kit		1	
17	3206 0308	Kit Serbatoio	Tank Assembly		1	
18	3200 0058	Tappo Detergente	Detergent Plug	Rosso / Red	1	
19	1407 0051	Vite Speciali Carenatura	Special Cover Screw		1	
20	2815 0026	Rivetto	Rivet	M5x13	1	
21	3002 0660	Supporto Carena	Cover Support		1	
22	3623 0031	Vite Speciale	Special Screw	M5x5	1	
23	1002 0177	Filtro Diesel	Diesel Filter		1	
24	3200 0123	Tappo Diesel	Diesel Plug	Nero / Black	1	

N°	Cod.	Descrizione	Description	Note	Qty	Model
25	3002 0659	Supporto	Support		1	
26	2811 0026	Rondella	Washer	Ø8,4x24x2	2	
27	2434 0003	Pressacavo	Cable Holder	PG16	1	
28	2800 0129	Raccordo p.g. Aspirazione	Straight Hose Tail	M8	2	
29	0604 0050	Dado	Nut	G3/4x7	1	
30	1002 0078	Filtro	Filter		1	
31	1209 0104	Guarnizione	Gasket	18x24x3	1	
32	2803 0371	Raccordo	Coupling	90°	1	
33	1223 0052	Galletto	Adjustable Nut	G3/4"	1	
34	3208 1082	Tubo Detergente	Detergent Hose	Ø7x10 L=850	1	
35	1003 0059	Fascetta	Hose Clamp		1	
36	3200 0073	Tappo	Plug	G3/4F"	1	
37	1209 0109	Guarnizione	Gasket	Ø24 h3,5	1	
38	0604 0050	Dado	Nut	G3/4x7	1	
39	1227 0002	Ghiera per Pressacavo	Ring Nut for Cable Holder	PG16	1	
40	2819 0028	Rondella	Washer	M8	2	
41	0604 0158	Dado	Nut	M8	2	
42	1003 0003	Fascetta	Hose Clamp		2	
43	3208 0898	Tubo Gasolio	Diesel Hose	Ø6x12 L=535	1	
44	3208 0893	Tubo Gasolio	Diesel Hose	Ø6x12 L=650	1	
45	1209 0140	Guarnizione	Gasket		1	



Pump	Model	Part No.
	RW 4025S	6.15 (6517 0402)
	RW 4030S	8.15 (6517 0403)
	RW 5030S	9.18 (6517 0601)
	RW 5525S	9.21 (6517 0702)
	RW 5030S	10.18 (6517 0602)
	RW 5530S	10.21 (6517 0806)

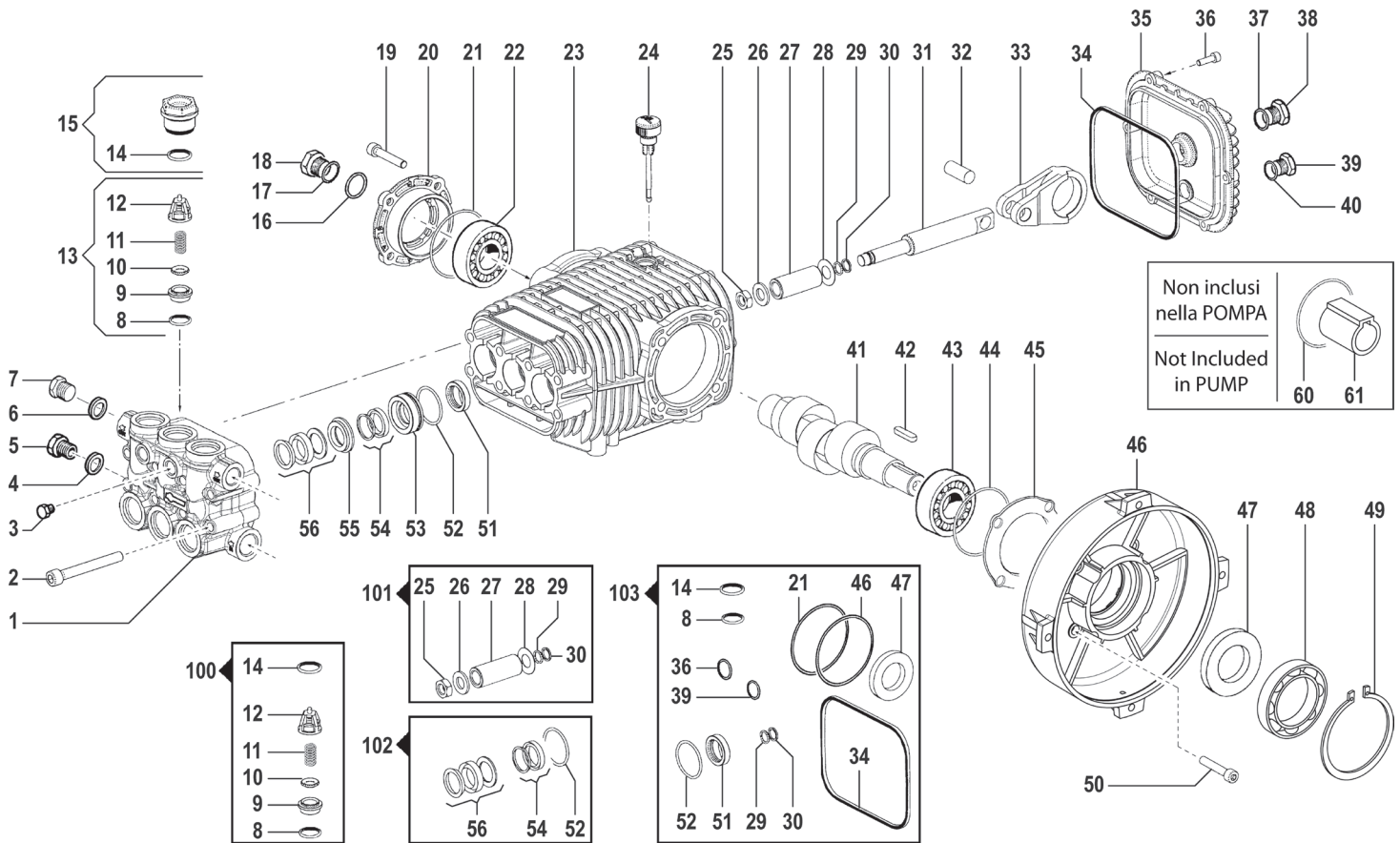

N°	Cod.	Descrizione	Description	Note	Qty	Model
1	3218 0373	Testata Pompa	Pump Manifold	Ø20	1	
2	3609 0039	Vite	Screw	M8x70	8	
3	3200 0004	Tappo	Plug	G1/4"	1	
4	2811 0086	Rondella in Rame	Copper Washer	Ø21,2x27x1,5	1	
5	3202 0015	Tappo	Plug	G1/2"	1	
6	2811 0084	Rondella	Washer	Ø16,7x22x1,5	1	
7	3200 0007	Tappo	Plug	G3/8	1	
8	1210 0046	Guarnizione OR	O-Ring	Ø2,62x17,13	6	
9	3009 0087	Sede Valvola Aspirazione/Mandata	Suction/Delivery Valve Seat		6	
10	3604 0017	Valvola Aspiraz./Mand.	Suction/Delivery Valve		6	
11	1802 0177	Molla Valvola Aspirazione/Mandata	Suction/Delivery Valve Spring		6	
12	1205 0025	Gabbia Valvola Aspirazione/Mand.	Suction/Delivery Valve Cage	Basse portate Low Flow	6	6.15 - 8.15
	1205 0043	Gabbia Valvola Aspirazione/Mandata	Suction/Delivery Valve Cage	Alte portate High Flow	6	9.18 - 9.21 10.18 - 10.21
13	1220 0030	Valvola Aspirazione/Mandata	Suction/Delivery Valve	Basse portate Low Flow	6	6.15 - 8.15
	1220 0072	Valvola Aspirazione/Mandata	Suction/Delivery Valve	Alte portate High Flow	6	9.18 - 9.21 10.18 - 10.21
14	1210 0048	Guarnizione OR	O-Ring	Ø2,62x20,24	6	
15	3202 0315	Kit Tappo Valvola Aspirazione/Mandata	Suction/Delivery Valve Plug Kit		6	
16	3019 0033	Seeger	Seeger	Ø28	1	
17	1210 0451	Guarnizione OR	O-Ring	Ø2x24	1	
18	3201 0026	Tappo Livello Olio	Oil Level Plug		1	
19	3609 0005	Vite	Screw	M8x20	4	
20	1009 0261	Flangia	Flange		1	
21	1210 0448	Guarnizione OR	O-Ring	Ø2x70	1	
22	0440 0031	Cuscinetto Rulli Conici	Roller Bearing	Ø30x62x21,25	1	
23	0403 0182	Carter Pompa	Pump Crankcase		1	
24	3200 0051	Tappo Olio	Oil Dipstick		1	
25	0600 0054	Dado Speciale	Special Bolt		3	
26	2811 0082	Rondella	Washer	Ø8,4x16x1,5	3	

N°	Cod.	Descrizione	Description	Note	Qty	Model
27	0202 0024	Bussola Ceramica	Ceramic Bushing	Ø20	3	
28	2812 0094	Rondella	Washer		3	
29	1210 0039	Guarnizione OR	O-Ring	Ø1,78x7,66	3	
30	0009 0170	Anello BK	Anti-Extr. Ring		3	
31	2409 0139	Pistone Guida	Piston		3	
32	3011 0016	Spinotto	Gudgeon Pin	Ø10x29	3	
33	0205 0044	Biella	Connecting Rod		3	
34	1210 0369	Guarnizione OR	O-Ring	Ø3,53x117,1	1	
35	0402 0307	Coperchio Carter	Cover		1	
36	3609 0030	Vite	Screw	M5x20	6	
37	1210 0048	Guarnizione OR	O-Ring	Ø2,62x20,24	1	
38	3201 0027	Tappo Livello Olio	Oil Level Plug	G1/2"	1	
39	3200 0007	Tappo	Plug	G3/8"	1	
40	1210 0441	Guarnizione OR	O-Ring	Ø2x14	1	
41	0001 0569	Albero Maschio	Solid Crankshaft	Ø24	1	6.15
	0001 0631	Albero Maschio	Solid Crankshaft	Ø24	1	8.15
	0001 0570	Albero Maschio	Solid Crankshaft	Ø24	1	9.18 - 10.18
	0001 0571	Albero Maschio	Solid Crankshaft	Ø24	1	9.21
	0001 0653	Albero Maschio	Solid Crankshaft	Ø24	1	10.21
42	1602 0013	Linguetta	Key	8x7x30	1	6.15 - 8.15 9.18 - 10.18
	1602 0055	Linguetta	Key	8x7x35	1	10.21
43	0440 0031	Cuscinetto Rulli Conici	Roller Bearing	Ø30x62x21,25	1	
44	1210 0448	Guarnizione OR	O-Ring	Ø2x70	1	
45	0601 0334	Distanziale	Spacer	sp. 0,05	1	
	0601 0335	Distanziale	Spacer	sp. 0,1	1	
	0601 0336	Distanziale	Spacer	sp. 0,19	1	
	0601 0337	Distanziale	Spacer	sp. 0,25	1	
46	1009 0255	Flangia Pompa/Motore	Pump/Motor Flange		1	6.15 - 8.15 9.18 - 9.21
	1009 0266	Flangia Pompa/Motore	Pump/Motor Flange		1	10.18 - 10.21
47	0019 0007	Anello Tenuta Olio	Oil Seal	Ø25x52x7	1	
48	0438 0106	Cuscinetto Sfere	Ball Bearing	Ø45x75x16	1	6.15 - 8.15 9.18 - 9.21
	0438 0113	Cuscinetto Sfere	Ball Bearing	Ø45x75x16	1	10.18 - 10.21



N°	Cod.	Descrizione	Description	Note	Q.ty	Model
49	3020 0036	Seeger	Seeger		1	
50	3609 0058	Vite	Screw	M8x22	4	
51	0019 0128	Anello Tenuta Olio	Oil Seal	Ø20x28x5	3	
52	1210 0156	Guarnizione OR	O-Ring	Ø1,78x31,47	3	
53	0009 0353	Anello Portaguarnizione	Packing Retainer	Ø20	3	
54	1241 0080	Guarnizione Tenuta	Packing	Ø20	3	
55	0009 0352	Anello Portaguarnizione	Packing Retainer	Ø20	3	
56	1241 0079	Guarnizione Tenuta	Packing	Ø20	3	

N°	Cod.	Descrizione	Description	Note	Q.ty	Model
60	1210 0618	Guarnizione OR	O-Ring	Ø1,5x42 Viton	2	
61	0204 0074	Bussola Sinterizzata	Sinterized Bushing		1	
Kit Ricambi						
<i>Spare Parts Kit</i>						
100	5025 0011	Kit Valvola Aspirazione/ Mandata	Complete Valve Kit	Basse portate Low Flow	1	6.15 - 8.15
	5025 0025	Kit Valvola Aspirazione/ Mandata	Complete Valve Kit	Alte portate High Flow	1	9.18 - 9.21 10.18 - 10.21
101	2409 0145	Kit Pistone	Piston Kit	Ø20mm	1	
102	5019 0672	Kit Guarnizioni Acqua	Water Seal Kit	Ø20mm	1	
103	5019 0675	Kit Guarnizioni Olio	Oil Seal Kit		1	

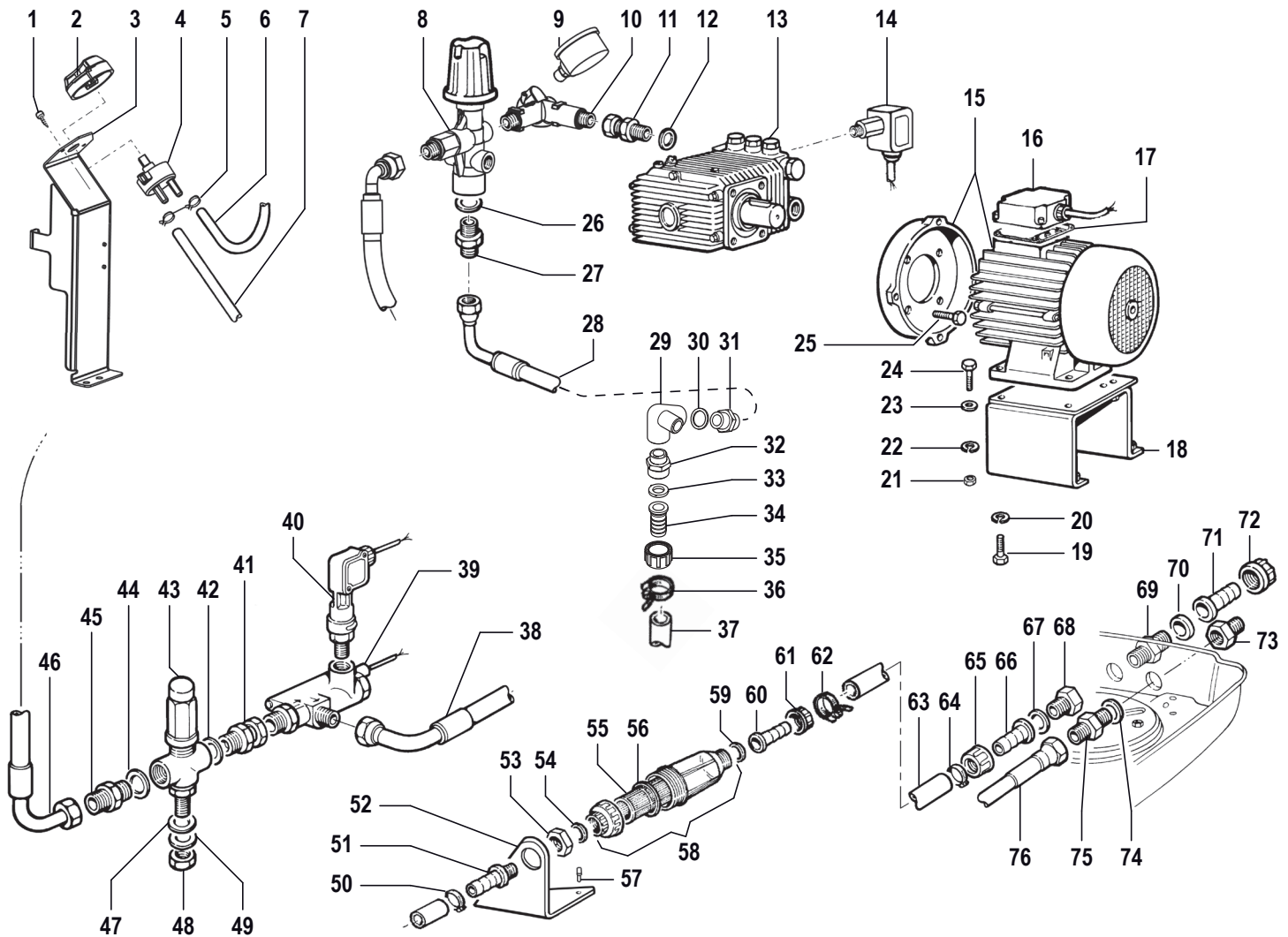

N°	Cod.	Descrizione	Description	Note	Q.ty	Model
1	3625 0036	Vite	Screw	Ø3,9x13	2	
2	1817 0082	Manopola	Knob		1	
3	3002 0651	Supporto	Support		1	
4	2826 0028	Kit Rubinetto Deterg.	Detergent Tap Kit		1	
5	1003 0059	Fascetta	Hose Clamp		2	
6	3208 1020	Tubo Detergente	Detergent Hose	Ø7x10 L=460	1	
7	3208 1082	Tubo Detergente	Detergent Hose	Ø7x10 L=830	1	
8	1215 0385	Valvola Regolazione	Regulation Valve Ass.y	VB 9	1	Senza Tanica Acqua Without Water Tank Fino a Matricola Up To S. Number 42731946
	1215 0534	Valvola Regolazione	Regulation Valve Ass.y	VRC25	1	Senza Tanica Acqua Without Water Tank Da Matricola From S. Number 42731947
9	1816 0132	Manometro	Pressure Gauge	Ø50 0-300bar G1/4	1	
10	0424 0447	Raccordo Speciale	Special Coupling		1	
11	0011 0003	Adattatore	Adapter	M/F G3/8"	1	
12	1209 0091	Guarnizione	Gasket	G3/8"	1	
13	6517 0402	Pompa	Pump	RW 4025 S	1	6.15
	6517 0403	Pompa	Pump	RW 4025 S	1	8.15
14	2421 0018	Pressostato (Blu)	Pressure Switch (Blue)	G1/4-15bar	1	

N°	Cod.	Descrizione	Description	Note	Q.ty	Model
15	1831 0649	Motore Elettrico	Electric Motor	TRF 400/50 6CV	1	6.15
	1831 0642	Motore Elettrico	Electric Motor	TRF 400/50 9CV	1	8.15
16	0402 0395	Coperchio Motore	Motor Cover		1	
17	1201 0190	Guarnizione	Seal		1	
18	3002 0633	Supporto	Support		1	
19	3607 0195	Vite Testa Esagonale	Hexagonal Screw	M10x20	4	
20	2819 0029	Rosetta Elastica	Spring Washer	Ø10,5x17,5x2,2	4	
21	0604 0105	Rondella	Washer	M10	4	
22	2811 0002	Rondella	Washer	Ø10,5x21x2	4	
23	2819 0001	Rosetta Elastica	Spring Washer	Ø10,5x17,5x2,2	4	
24	3607 0227	Vite Testa Esagonale	Hexagonal Screw	M10x40	4	
25	3609 0058	Vite	Screw	M8x22	4	
26	1209 0091	Guarnizione	Gasket	G3/8"	1	
27	2000 0041	Nipplo	Nipple	G3/8-G3/8"	1	
28	3208 1081	Tubo By-pass	By-pass Hose	L=430 G3/8"	1	
29	2803 0168	Raccordo	Coupling	G1/2M-G1/2F-G3/8"	1	
30	1209 0091	Rondella	Washer	G3/8"	1	
31	2000 0041	Nipplo	Nipple	G3/8"	1	
32	2000 0056	Nipplo	Nipple	M-M G3/4"-G1/2" L=31	1	
33	1209 0111	Guarnizione	Gasket	Ø14,5x24,5x3,5	1	
34	2800 0098	Raccordo p.g. Aspir.	Straight Hose Tail	Ø19	1	
35	1223 0052	Galletto	Wing Nut	G3/4"	1	
36	1003 0069	Fascetta	Hose Clamp	Ø26	1	
37	3208 1038	Tubo Aspirazione	Suction Hose	Ø19x26 L=380	1	



Motorpump without water tank

N°	Cod.	Descrizione	Description	Note	Qty	Model
38	3208 0922	Tubo Alta Pressione	High Pressure Hose	R2 3/8" L=300	1	
39	2421 0017	Flussostato	Flow Switch	M/M G3/8-G3/8	1	
40	2421 0018	Pressostato (Blu)	Pressure Switch (Bleu)	G1/4-15bar	1	
41	0011 0003	Adattatore	Adapter	M/F G3/8+OGV	1	
42	1209 0091	Guarnizione	Gasket	G3/8"	1	
43	1215 0275	Valvola di Sicurezza	Safety Valve	G3/8F-G1/4M	1	
44	1209 0091	Guarnizione	Gasket	G3/8"	1	
45	2000 0041	Nipplo	Nipple	G3/8"-G3/8"	1	
46	3208 1140	Tubo Alta Pressione	High Pressure Hose	5/16" L=530	1	
47	2811 0010	Rondella	Washer	Ø15x28	1	
48	0600 0005	Dado Speciale	Special Bolt	G1/4"	1	
49	2811 0010	Rondella	Washer	Ø15x28	1	
50	1003 0069	Fascetta	Hose Clamp	Ø26	1	
51	2800 0035	Raccordo	Coupling	G3/4 - Ø19	1	
52	3002 0675	Staffa Filtro Acqua	Water Filter Bracket		1	
53	0604 0050	Dado	Nut	G3/4 x7	1	
54	1209 0111	Guarnizione	Gasket	Ø14,5x24,5x3,5	1	
55	1002 0122	Filtro Aspirazione	Suction Filter		1	
56	1209 0106	Guarnizione	Gasket	Ø29x50x2	1	
57	2815 0011	Rivetto	Rivet	Ø19x26 L=400	3	

N°	Cod.	Descrizione	Description	Note	Qty	Model
58	1002 0129	Kit Filtro Aspirazione	Suction Filter Kit	G3/4	1	
59	1209 0111	Guarnizione	Gasket	Ø14,5x24,5x3,5	1	
60	2800 0098	Raccordo p.g. Aspir.	Straight Hose Tail	Ø19	1	
61	1223 0052	Galletto	Wing Nut	G3/4"	1	
62	1003 0069	Fascetta	Hose Clamp	Ø26	1	
63	3208 0812	Tubo Aspirazione	Suction Hose	Ø19x26 L=180	1	
64	1003 0069	Fascetta	Hose Clamp	Ø26	1	
65	1223 0052	Galletto	Wing Nut	G3/4"	1	
66	2800 0098	Raccordo p.g. Aspir.	Straight Hose Tail	Ø19	1	
67	1209 0111	Guarnizione	Gasket	Ø14,5x24,5x3,5	1	
68	2825 0051	Riduzione M/F	M/F Reduction	G3/4-G1/2"	1	
69	2000 0056	Nipplo	Nipple	G3/4M- G1/2M"	1	
70	1209 0111	Guarnizione	Gasket	Ø14,5x24,5x3,5	1	
71	2800 0098	Raccordo p.g. Aspir.	Straight Hose Tail	Ø19 - G3/4F	1	
72	1223 0052	Galletto	Wing Nut	G3/4"	1	
73	2803 0256	Raccordo	Coupling	M22x1,5-G3/8"	1	
74	1209 0091	Rondella	Washer	G3/8"	1	
75	2000 0041	Nipplo	Nipple	M/M - G3/8"	1	
76	3208 0856	Tubo Alta Pressione	High Pressure Hose	5/16" L=290	1	

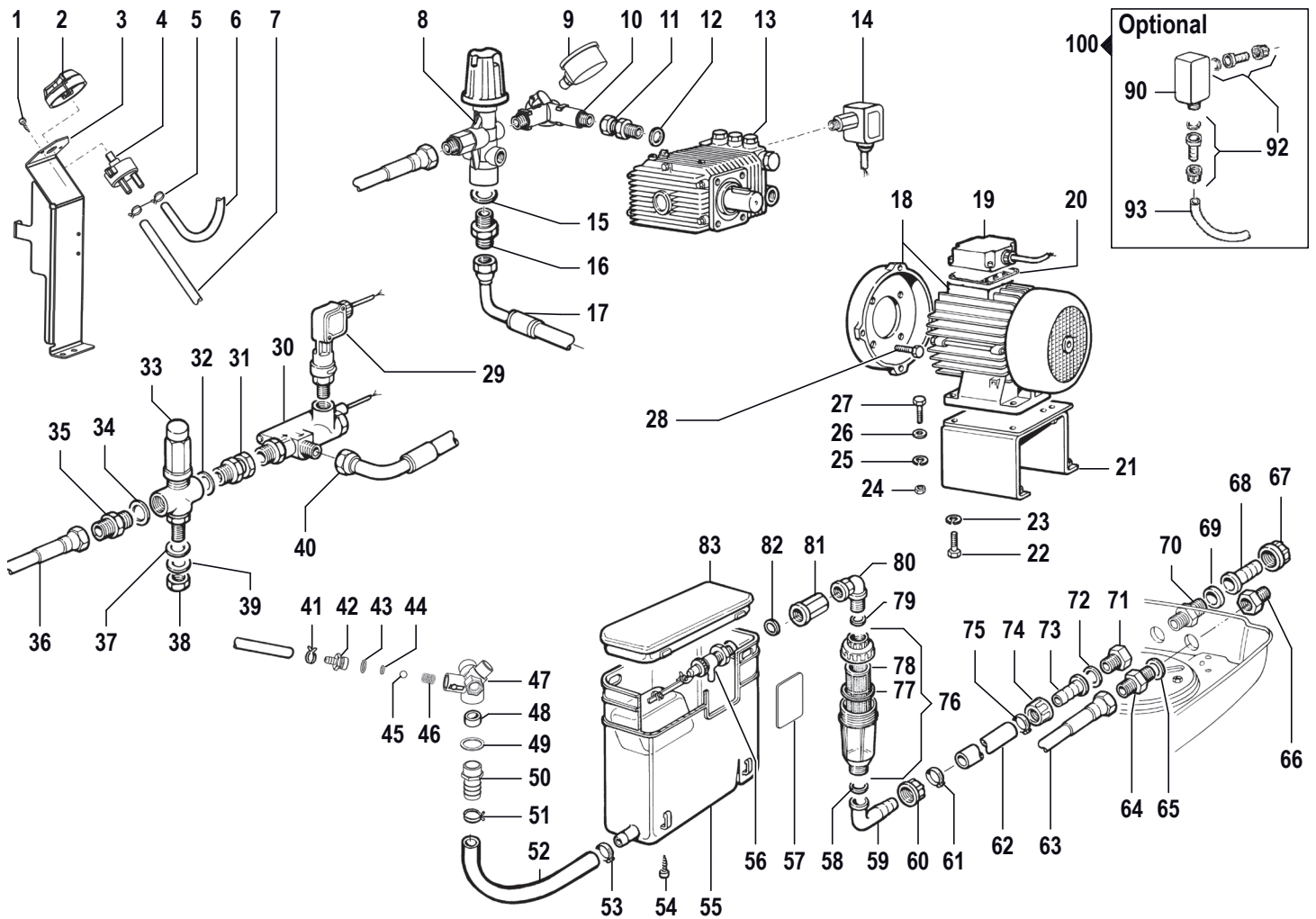

N°	Cod.	Descrizione	Description	Note	Q.ty	Model
1	3625 0036	Vite	Screw	Ø3,9x13	2	
2	1817 0082	Manopola	Knob		1	
3	3002 0651	Supporto	Support		1	
4	2826 0036	Kit Rubinetto Deterg.	Detergent Tap Kit		1	
5	1003 0059	Fascetta	Hose Clamp		2	
6	3208 1168	Tubo Detergente	Detergent Hose	Ø7x10 L=130	1	
	3208 1167	Tubo Detergente	Detergent Hose	Ø7x10 L=185	1	Solo / Only 10.18 - 10.21
7	3208 1082	Tubo Detergente	Detergent Hose	Ø7x10 L=830	1	
8	1215 0418	Valvola Regolazione	Regulation Valve Ass.y	VB 9	1	Con Tanica Acqua With Water Tank
						Fino a Matricola Up To S. Number 42714341
	1215 0540	Valvola Regolazione	Regulation Valve Ass.y	VRC25	1	Con Tanica Acqua With Water Tank Da Matricola From S. Number 42714342
9	1816 0132	Manometro	Pressure Gauge	Ø50 G1/4 0-315bar	1	
10	0424 0447	Raccordo Speciale	Special Coupling		1	6.15 - 8.15 9.18 - 9.21
	0424 0464	Raccordo Speciale	Special Coupling		1	10.18 - 10.21
11	0011 0003	Adattatore	Adapter	M/F G3/8"	1	

N°	Cod.	Descrizione	Description	Note	Q.ty	Model
12	1209 0091	Guarnizione	Gasket	3/8"	1	
13	6517 0402	Pompa	Pump	RW 4025 S	1	6.15
	6517 0403	Pompa	Pump	RW 4025 S	1	8.15
	6517 0601	Pompa	Pump	RW 5030 S	1	9.18
	6517 0702	Pompa	Pump	RW 5525 S	1	9.21
	6517 0602	Pompa	Pump	RW 5030 S	1	10.18
	6517 0806	Pompa	Pump	RW 5530 S	1	10.21
14	2421 0038	Pressostato (Blu)	Pressure Switch (Bleu)	G1/4-15bar	1	
15	1209 0091	Guarnizione	Gasket	G3/8"	1	
16	2000 0041	Nipplo	Nipple	G3/8-G3/8"	1	
17	3208 1139	Tubo By-pass	By-pass Hose	L=700 G3/8"	1	
18	1831 0649	Motore Elettrico	Electric Motor	TRF 400/50 6CV	1	6.15
	1831 0642	Motore Elettrico	Electric Motor	TRF 400/50 9CV	1	8.15 - 9.18 9.21
	1831 0527	Motore Elettrico	Electric Motor	TRF 400/50 10CV	1	10.18 - 10.21
19	0402 0395	Coperchio Motore	Motor Cover		1	6.15 - 9.18 9.21 - 10.18 10.21
	0402 0465	Coperchio Motore	Motor Cover		1	8.15
20	1201 0190	Guarnizione	Seal		1	6.15 - 8.15 9.18 - 9.21 10.18 - 10.21
21	3002 0633	Supporto	Support		1	6.15 - 8.15 9.18 - 9.21
	3002 0693	Supporto	Support		1	10.18 - 10.21
22	3607 0195	Vite Testa Esagonale	Hexagonal Screw	M10x20	4	
23	2819 0029	Rosetta Elastica	Spring Washer	10,5x17,5x2,2	4	
24	0604 0105	Rondella	Washer	M10	4	



N°	Cod.	Descrizione	Description	Note	Qty	Model
25	2811 0002	Rondella	Washer	Ø10,5x20x2	4	
26	2819 0001	Rosetta Elastica	Spring Washer	Ø10,5x17,5x2,2	4	
27	3607 0227	Vite Testa Esagonale	Hexagonal Screw	M10x40	4	
28	3609 0058	Vite	Screw	M8x22	4	
29	2421 0038	Pressostato (Blu)	Pressure Switch (Bleu)	G1/4-15bar	1	
30	2421 0017	Flussostato	Flow Switch	M/M G3/8-G3/8	1	
31	0011 0003	Adattatore	Adapter	M/F G3/8+OGV	1	
32	1209 0091	Guarnizione	Gasket	3/8"	1	
33	1215 0275	Valvola di Sicurezza	Safety Valve	G3/8F-G1/4M	1	
34	1209 0091	Guarnizione	Gasket	3/8"	1	
35	2000 0041	Nipplo	Nipple	G3/8"-G3/8"	1	
36	3208 1140	Tubo Alta Pressione	High Pressure Hose	5/16" L=530	1	6.15 - 8.15 9.15
	3208 1124	Tubo Alta Pressione	High Pressure Hose	3/8" L=580	1	9.21 - 10.18 10.21
37	2811 0010	Rondella	Washer	15x28	1	
38	0600 0005	Dado Speciale	Special Bolt	G1/4"	1	
39	2811 0010	Rondella	Washer	15x28	1	
40	3208 0886	Tubo Alta Pressione	High Pressure Hose	R2 5/16" L=300	1	6.15 - 8.15 9.18
	3208 0922	Tubo Alta Pressione	High Pressure Hose	R2 3/8" L=300	1	9.21 - 10.18 10.21
41	1003 0059	Fascetta	Hose Clamp		1	
42	2800 0515	Raccordo Detergente	Detergent Coupling		1	
43	1210 0170	Guarnizione OR	O-ring Seal	Ø1,78x10,82	1	
44	1210 0072	Guarnizione OR	O-ring Seal	Ø2x6	1	
45	3003 0043	Sfera	Ball	5/16"	1	
46	1802 0228	Molla	Spring		1	
47	0424 0466	Raccordo Aspirazione	Suction Coupling		1	
48	0601 0401	Distanziale	Spacer	Ø18x7,5 H6,5	1	6.15 - 8.15 9.15
	0601 0400	Distanziale	Spacer	Ø18x8,5 H6,5	1	9.21 - 10.18 10.21
49	1209 0114	Rondella in Rame	Copper Washer	G1/2"	1	
50	2800 0120	Raccordo	Coupling			
51	1003 0066	Fascetta	Hose Clamp	Ø26	1	
52	3208 1105	Tubo Aspirazione	Suction Hose	Ø19x26 L=230	1	
53	1003 0066	Fascetta	Hose Clamp	Ø26	1	
54	3625 0075	Vite	Screw	Ø4,2x16	4	
55	0461 0569	Cisterna Acqua	Water Tank		1	

N°	Cod.	Descrizione	Description	Note	Qty	Model
56	1237 0010	Kit Galleggiante	Floater Kit	3/4"	1	
57	0402 0349	Coperchio Laterale	Water Tank Lid		1	
58	1209 0111	Guarnizione	Gasket	Ø14,5x24,5x3,5	1	
59	2801 0074	Raccordo p.g. Curvo	Elbow Coupling	Ø19-G3/4"F	1	
60	1223 0052	Galletto	Wing Nut	G3/4"	1	
61	1003 0018	Fascetta	Hose Clamp	Ø20-32	1	
62	3208 0229	Tubo Aspirazione	Suction Hose	Ø19x26 L=250	1	
63	3208 0856	Tubo Alta Pressione	High Pressure Hose	5/16" L=290	1	6.15 - 8.15 9.15
	3208 1109	Tubo Alta Pressione	High Pressure Hose	3/8" L=272	1	9.21 - 10.18 10.21
64	2000 0041	Nipplo	Nipple	M/M - G3/8"	1	Solo / Only 6.15 - 8.15 9.18
65	1209 0091	Rondella	Washer	G3/8"	1	
66	2803 0256	Raccordo	Coupling	M22x1,5-G3/8"	1	
67	1223 0052	Galletto	Wing Nut	G3/4"	1	
68	2800 0098	Raccordo p.g. Aspir.	Straight Hose Tail	Ø19-G3/4"F	1	
69	1209 0111	Guarnizione	Gasket	Ø14,5x24,5x3,5	1	
70	2000 0056	Nipplo	Nipple	M/M G3/4"-G1/2"	1	
71	2825 0051	Riduzione M/F	M/F Reduction	G3/4"-G1/2"	1	
72	1209 0111	Guarnizione	Gasket	Ø14,5x24,5x3,5	1	
73	2800 0098	Raccordo p.g. Aspir.	Straight Hose Tail	Ø19	1	
74	1223 0052	Galletto	Wing Nut	G3/4"	1	
75	1003 0018	Fascetta	Hose Clamp	Ø20-32	1	
76	1002 0129	Kit Filtro Aspirazione	Suction Filter Kit	G3/4"	1	
77	1209 0106	Guarnizione	Gasket	Ø29x50x2	1	
78	1002 0122	Filtro Aspirazione	Suction Filter		1	
79	1209 0111	Guarnizione	Gasket	Ø14,5x24,5x3,5	1	
80	1211 0035	Gomito	Elbow	90° M/F G3/4"	1	
81	2417 0075	Prolunga	Extension	M/F G3/4"	1	
82	1210 0029	Guarnizione OR	O-ring Seal	Ø2,62x25,07	1	
83	0402 0251	Coperchio Vaschetta	Water Tank Cover		1	
90	0802 0012	Elettrovalvola Detergente	Detergent Electrovalve	24V	1	OPTIONAL
91	2803 0519	Kit Raccordo + Guarn.	Coupling Kit + Seal		2	
92	3208 1019	Tubo Detergente	Detergent Hose	Ø7x10 L=950	1	
100	0802 0015	Kit Elettrovalvola Deterg.	Deterg. Electrov. Kit	24V	1	

KF Classic

Valvola Regolazione VB9



VB 9 Valvola regolazione con Eiettore

VB 9 Unloader Valve with Injector

(1215 0385)

VB 9 Valvola Regolazione senza Eiettore

VB 9 Unloader Valve without Injector

(1215 0418)

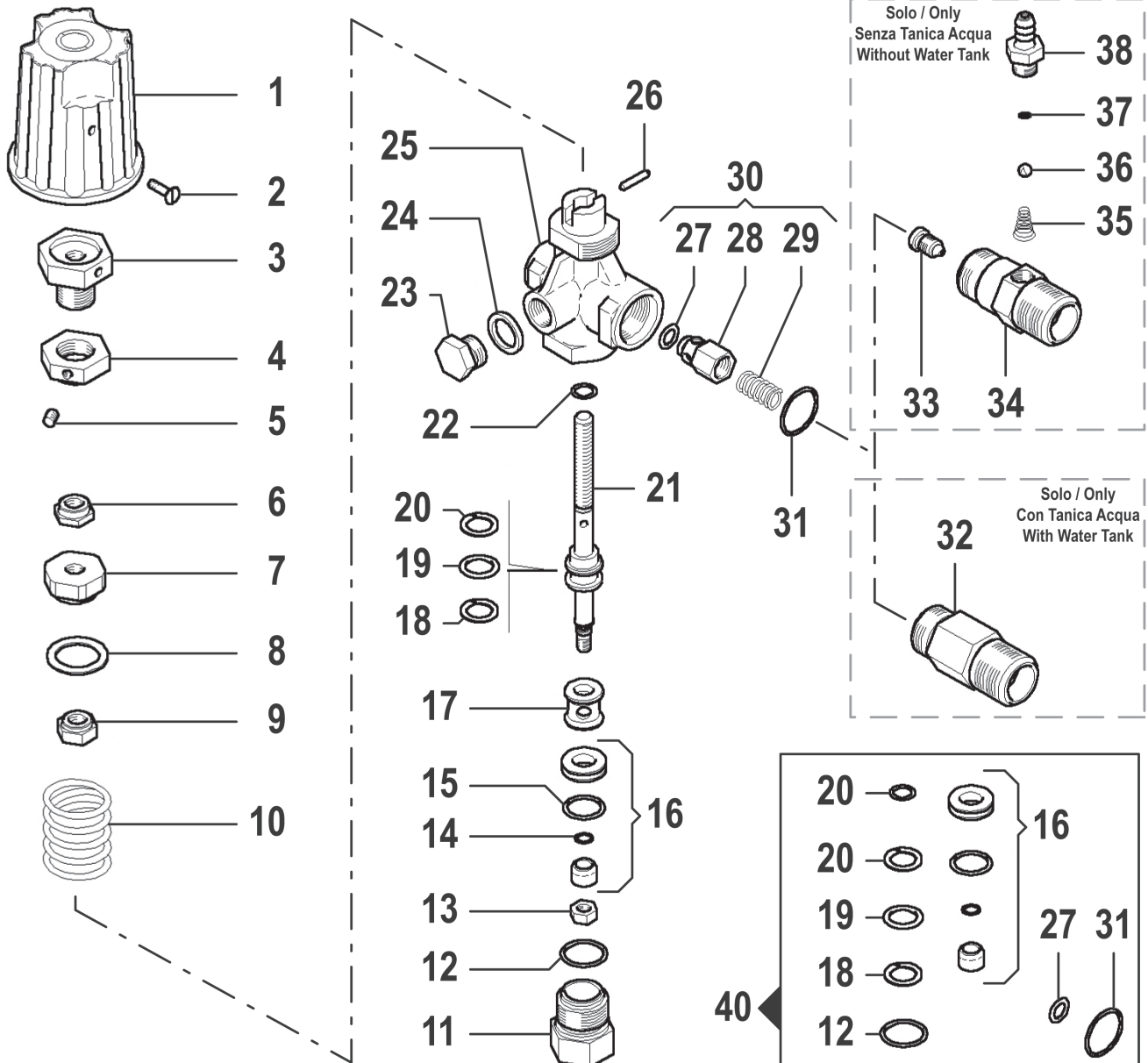

N°	Cod.	Descrizione	Description	Note	Qty	Model
1	1817 0059	Manopola	Knob		1	
2	3623 0007	Vite	Screw	M4x10	1	
3	3036 0014	Sede	Seat		1	
4	1227 0032	Ghiera	Ring Nut	M16x1	1	
5	3622 0041	Vite senza Testa Es. Inc.	Stop Adjustable Nut	M5x6	1	
6	0604 0039	Dado	Nut	M8x9,5	1	
7	2811 0111	Rondella Tranc.	Washer	19x26x1,5	1	
8	1227 0031	Ghiera	Ring Nut	M8x1,25	1	
9	1802 0200	Molla	Spring	Ø4,2x23,2x31	1	
10	3202 0320	Tappo	Plug		1	
11	1210 0233	Guarnizione OR	O-Ring	Ø1,78x18,77	1	
12	0604 0095	Dado	Nut	M6	1	
13	1210 0421	Guarnizione OR	O-Ring	1x4	1	
14	1210 0708	Guarnizione OR	O-Ring		1	
15	3009 0162	Kit Sede Valvola Regol.	Valve Seat Kit		1	
16	0601 0321	Distanziale	Spacer		1	
17	0009 0183	Anello	Ring		1	
18	1210 0584	Guarnizione OR	O-Ring	Ø2,62x10,77	1	
19	0009 0183	Anello	Ring		1	
20	2409 0135	Asta Valvola	Unloader Valve Rod		1	
21	1210 0709	Guarnizione OR	O-Ring	Ø2,62x7,6	1	
22	3202 0321	Tappo	Plug	G1/4"	1	
23	2811 0130	Rondella	Washer	13,5x19x1,5	1	
24	0424 0441	Corpo	Body		1	
25	3021 0019	Spina Elastica	Elastic Pin	Ø3x14	1	

N°	Cod.	Descrizione	Description	Note	Qty	Model
27	1210 0189	Guarnizione OR	O-Ring	Ø3x6	1	
28	3600 0056	Valvola Non Ritorno	Check Valve		1	
29	1802 0161	Molla Valvola	Valve Spring		1	
30	3600 0099	Kit Valvola	Regulation Valve		1	
31	1210 0233	Guarnizione OR	O-Ring	Ø1,78x18,77	1	
32	2803 0236	Raccordo	Coupling	G3/8"F	1	Solo / only Con Tanica Acqua With Water Tank
33	3400 0291	Ugello Eiettore	Injector Nozzle	Ø1,8 mm	1	Solo / only Senza Tanica Acqua Without Water Tank
34	2803 0380	Raccordo	Coupling		1	
35	1802 0140	Molla Conica	Conical Spring		1	
36	3003 0024	Sfera	Ball		1	
37	1210 0155	Guarnizione OR Viton®	Viton® O-Ring	Ø1,78X5,28	1	
38	2803 0306	Raccordo Detergente	Detergent Coupling		1	

Kit Ricambi Spare Parts Kit

40	5015 0026	Kit Manutenzione Valvola	Valve Maintenance Kit		1	
----	-----------	--------------------------	-----------------------	--	---	--

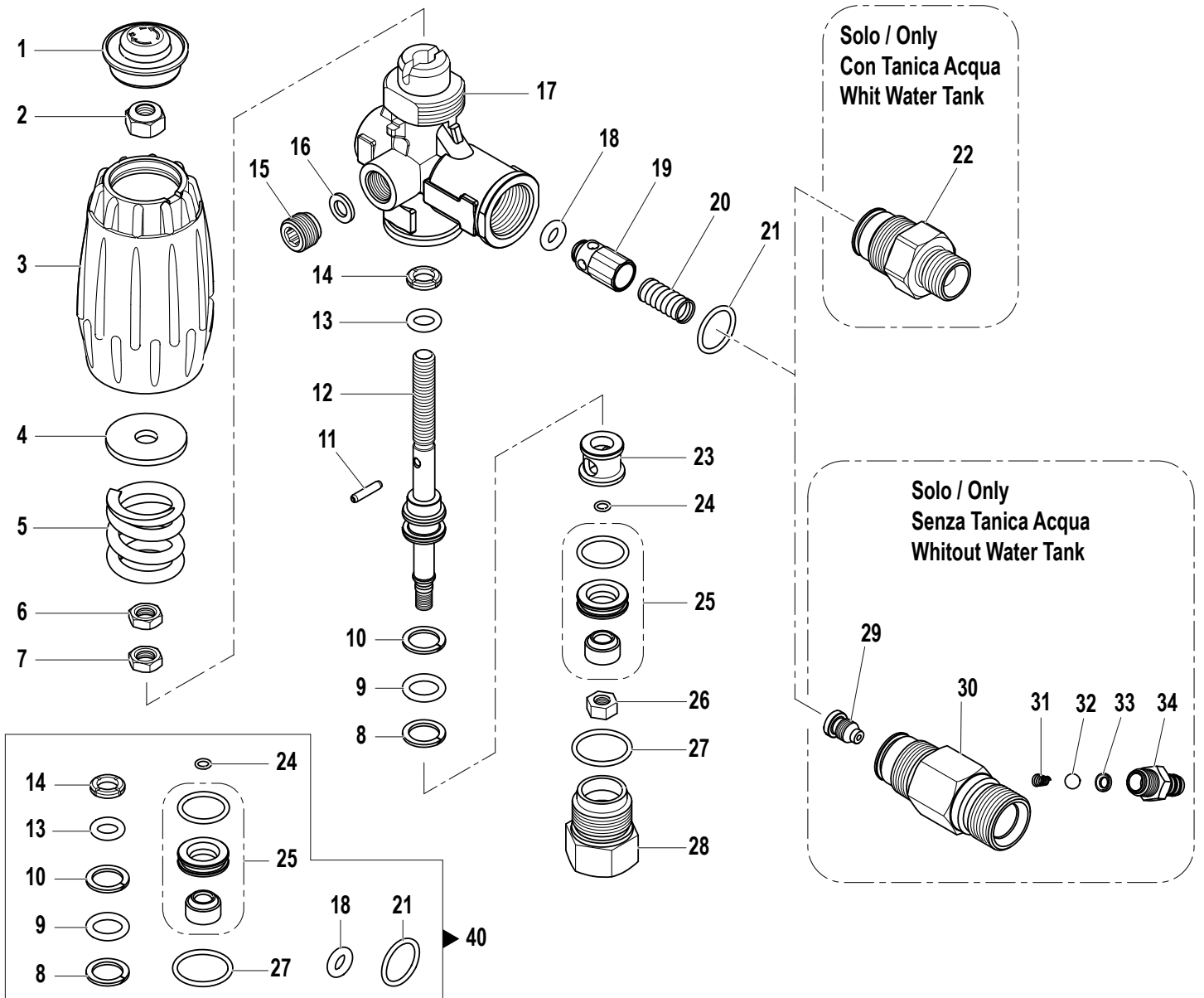

N°	Cod.	Descrizione	Description	Note	Q.ty	Model
1	0402 0474	Tappo	Plug		1	
2	0604 0039	Dado	Nut	M8x9,5	1	
3	1817 0093	Manopola	Knob		1	
4	2812 0127	Rondella Speciale	Special Washer	Ø8,3x30x2,5	1	
5	1802 0342	Molla	Spring		1	
6	0604 0164	Dado	Nut	M8	1	
7	0604 0164	Dado	Nut	M8	1	
8	0009 0183	Anello	Ring		1	
9	1210 0057	Guarnizione OR	O-Ring	Ø2,62x10,78	1	
10	0009 0183	Anello	Ring		1	
11	3021 0019	Spina Elastica	Elastic Pin	Ø3x14	1	
12	0015 0217	Asta Valvola	Unloader Valve Rod		1	
13	1210 0719	Guarnizione OR	O-Ring	Ø2,6x7,6	1	
14	0009 0737	Anello	Ring		1	
15	3622 0058	Tappo	Cap	G1/4"	1	
16	2812 0128	Rondella Speciale	Special Washer	Ø6,5x11,4x1,5	1	
17	0424 0505	Corpo	Body		1	
18	1210 0570	Guarnizione OR	O-Ring	Ø3x6	1	

N°	Cod.	Descrizione	Description	Note	Q.ty	Model
19	3600 0115	Valvola Non Ritorno	Check Valve		1	
20	1802 0290	Molla	Spring		1	
21	1210 0708	Guarnizione OR	O-Ring	Ø1,78x15,6	1	
22	2803 0639	Raccordo	Coupling	G3/8"	1	
23	0601 0415	Distanziale	Spacer		1	
24	1210 0597	Guarnizione OR	O-Ring	Ø1x4	1	
25	3009 0218	Kit Sede Valvola	Valve Seat Kit		1	
26	0604 0104	Dado	Nut	M8	1	
27	1210 0233	Guarnizione OR	O-Ring	Ø1,78x18,77	1	
28	3202 0401	Tappo	Plug		1	

Kit Ricambi Spare Parts Kit

30	5015 0050	Kit Manutenzione Valvola	Valve Maintenance Kit		1	
----	-----------	--------------------------	-----------------------	--	---	--

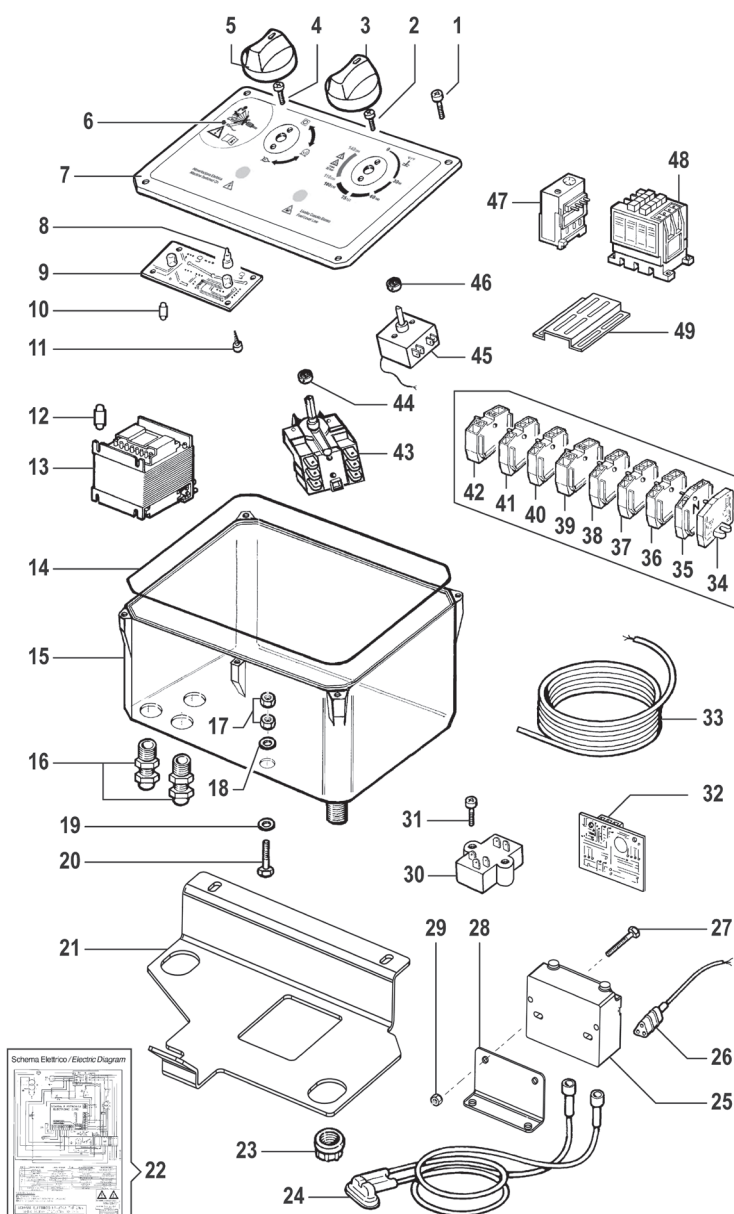

N°	Cod.	Descrizione	Description	Note	Q.ty	Model
1	3625 0035	Vite	Screw	3,5x19	6	
2	3623 0007	Vite	Screw	M4x10	2	
3	1817 0081	Manopola Potenziometro	Potentiometer Knob		1	
4	3623 0007	Vite	Screw	M4x10	2	
5	1817 0081	Manopola Interruttore	Switch Knob		1	
6	0457 0047	Etichetta Quadro Elettr.	Electrical Panel Sticker		1	
7	0402 0242	Coperchio	Cover		1	
8	1607 0002	Lampadina	Lamp		2	
9	3043 0028	Scheda Spie	Lamp Card		1	
10	1012 0031	Fusibile Scheda Elettronica	P.C. Board Fuse	5x20F-1,6A	1	
11	3625 0031	Vite	Screw	3,5x9,5	4	
12	1012 0003	Fusibile Trasformatore	Transformer Fuse	5x20F-2A	1	
13	3226 0084	Trasformatore B.T.	L.T. Transformer	230-400V/24V	1	
14	1201 0142	Guarnizione	Gasket		1	
15	3001 0148	Scatola Elettrica	Electrical Box		1	
16	2434 0003	Pressacavo Cavo Elettr.	Cable Holder	PG16	2	
17	0604 0061	Dado	Nut	M5x5	4	
18	2819 0009	Rosetta Elastica	Spring Washer	Ø5,3x10	3	
19	2811 0037	Rondella	Washer	Ø5,3x10	1	
20	3607 0234	Vite Testa Esagonale	Hexagonal Screw	M5x30	1	
21	3002 0650	Supporto	Support		1	
22	1610 1134	Schema Elettrico	Electric Diagram	TRF 400/50	1	
23	1223 0052	Galletto	Adjustable Nut		2	
24	0535 0073	Kit Cavo Elettrodo	Electrode Cable Kit		1	
25	3226 0082	Trasformatore A.T.	H.T. Transformer	230V-50/60HZ	1	
26	0456 0361	Cavo Trasform. A.T.	H.T. Transformer Cable	L=800	1	
27	3609 0199	Vite	Screw	M5x40	2	
28	3002 0672	Supporto x Trasformatore A.T.	H.T. Transformer Support		1	
29	0604 0061	Dado	Nut	M5x5	2	
30	1002 0118	Filtro Anti-disturbo	Electronic Filter		1	
31	3625 0050	Vite	Screw	4,2x9,5	2	
32	3043 0002	Scheda Elettronica	P.C. Board		1	
33	0456 0247	Cavo Elettrico	Electrical Cable	TRF 2,5mm ² L=6,8m	1	
34	1805 0040	Morsetto Chiusura	End Wire Connector	Grigio / Grey	1	
35	1805 0041	Morsetto	Wire Connector	Grigio / Grey	1	
36	1805 0041	Morsetto	Wire Connector	Grigio / Grey	1	
37	1805 0041	Morsetto	Wire Connector	Grigio / Grey	1	
38	1805 0041	Morsetto	Wire Connector	Grigio / Grey	1	
39	1805 0041	Morsetto	Wire Connector	Grigio / Grey	1	
40	1805 0041	Morsetto	Wire Connector	Grigio / Grey	1	
41	1805 0042	Morsetto Chiusura	End Wire Connector	Blu / Blue	1	
42	1805 0043	Morsetto	Wire Connector	Grigio / Grey	1	
43	1410 0147	Interruttore 0-1-2	0-1-2 Switch		1	
44	0204 0041	Boccola	Bushing-Seal		1	
45	3230 0042	Termostato	Thermostat		1	
46	0204 0041	Boccola	Bushing-Seal		1	
47	2821 0043	Relé	Relay	13 / 18 Amp	1	8.15 - 9.18 9.21
	2821 0042	Relé	Relay	9 / 14 Amp	1	6.15
	2821 0044	Relé	Relay	17 / 23 Amp	1	10.18 - 10.21
48	3225 0075	Teleruttore	Remote Control Switch	18A 24V 50/60HZ	1	6.15 - 8.15 9.18 - 9.21
	3225 0078	Teleruttore	Remote Control Switch	25A 24V 50/60HZ	1	10.18 - 10.21
49	2404 0168	Staffa Teleruttore	Remote Control Bracket		1	

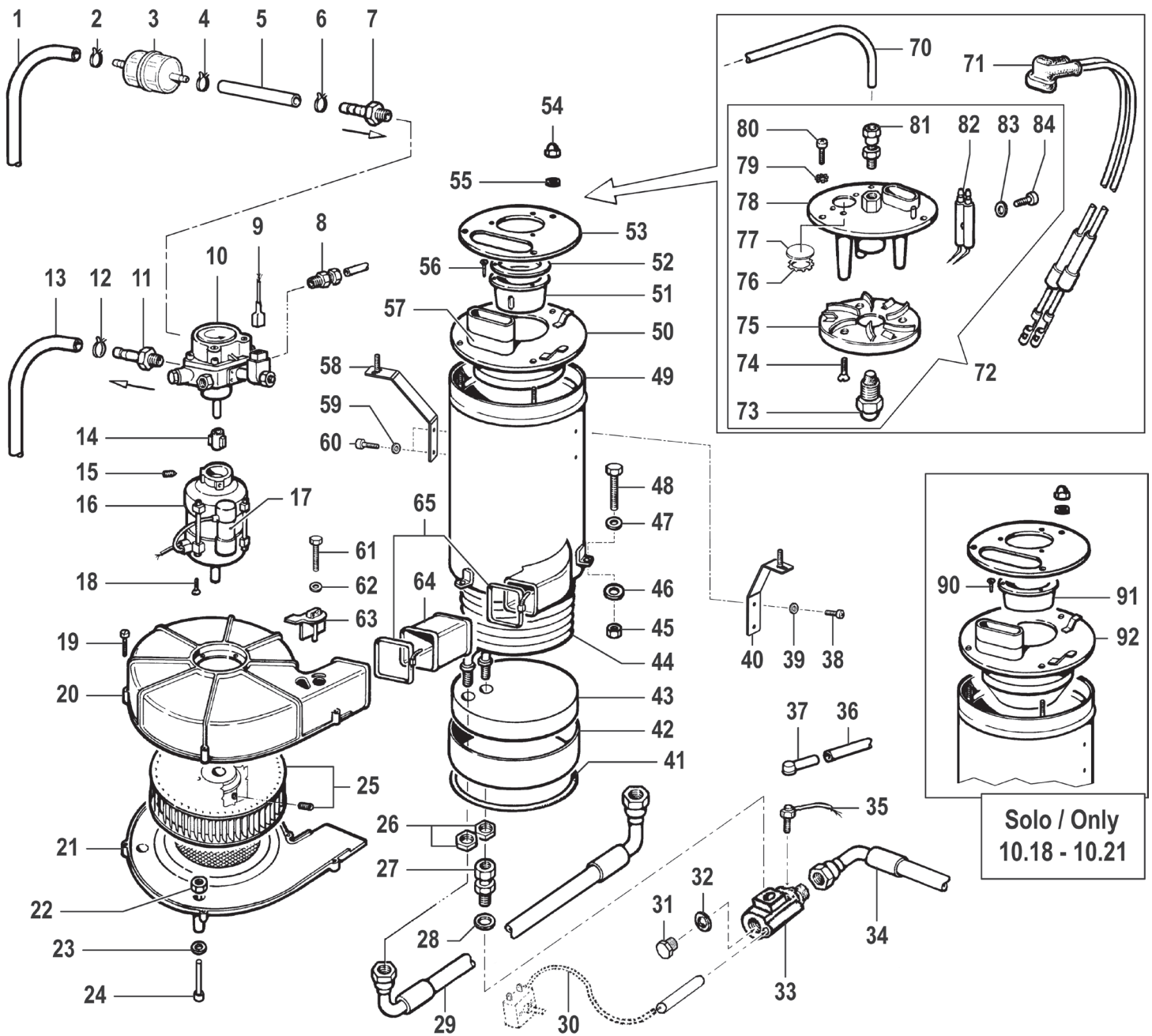

Solo / Only
10.18 - 10.21

N°	Cod.	Descrizione	Description	Note	Q.ty	Model
1	3208 0898	Tubo Gasolio	Diesel Hose	Ø6x12 L=535	1	
2	1003 0003	Fascetta	Hose Clamp		1	
3	1002 0120	Filtro Gasolio	Diesel Filter	15 Micron	1	
4	1003 0003	Fascetta	Hose Clamp		1	
5	3208 0892	Tubo Gasolio	Diesel Hose	Ø6x12 L=90	1	
6	1003 0003	Fascetta	Hose Clamp		1	
7	2803 0408	Raccordo p.g.	Coupling	G1/4 PG Ø7	1	
8	2803 0322	Raccordo	Coupling	Ø4 GC1/8"	1	
9	0430 0057	Connettore	Connector		1	
10	2422 0033	Kit Pompa Gasolio	Diesel Pump Kit		1	
11	2803 0570	Raccordo p.g.	Coupling	G1/4 PG Ø7	1	
12	1003 0003	Fascetta	Hose Clamp		1	
13	3208 0893	Tubo Gasolio	Diesel Hose	Ø6x12 L=650	1	
14	1221 0017	Giunto	Coupling		1	
15	3622 0029	Vite senza Testa Es. Inc.	Stop Adjustable Nut	M5x10	3	
16	1831 0555	Motore Elettrico	Electric Motor	230V 50Hz	1	
17	0434 0016	Condensatore	Condenser	6,3mF 450V 50/60Hz	1	
18	3608 0005	Vite	Screw	M4x10	4	

N°	Cod.	Descrizione	Description	Note	Q.ty	Model
19	3625 0028	Vite	Screw	3,5x25	5	
20	0404 0031	Convogliatore Super.	Shraud Cover		1	
21	0466 0025	Convogliatore Inf.	Shraud Cover		1	
22	0604 0010	Dado	Nut	M6	3	
23	2811 0125	Rondella	Washer	Ø6,4x12,5x1,6	3	
24	3609 0201	Vite	Screw	M6x60	3	
25	3632 0105	Kit Ventola + grano	Fan Kit + Grano	Ø200x45	1	
	3632 0118	Kit Ventola + grano	Fan Kit + Grano	Ø208x45	1	Solo / Only 10.18 - 10.21
26	1227 0035	Ghiera Fiss. Serpentina	Coil-Lock Nut	G3/8x8	2	
27	0011 0006	Adattatore	Adapter	M/F G1/4-3/8"	1	
28	1209 0113	Rondella in Rame	Copper Washer	G1/4"	1	
29	3208 0886	Tubo A.P.	H.P. Hose	R2 5/16" L=300	1	6.15 - 8.15 9.18
	3208 0922	Tubo A.P.	H.P. Hose	R2 3/8" L=300	1	9.21 - 10.18 10.21
30	3230 0042	Termostato	Thermostat		1	
31	3200 0102	Tappo	Cap	G1/4"	1	
32	1209 0097	Rondella con Guarnizione	Washer with Seal	G1/4"	1	



Bolier

N°	Cod.	Descrizione	Description	Note	Q.ty	Model
33	0424 0377	Corpo porta Termostato	Thermostat Body	Brass	1	
34	3208 0856	Tubo A.P.	H.P. Hose	R2 5/16" L=290	1	
	3208 1109	Tubo A.P.	H.P. Hose	R2 3/8" L=272	1	Solo / Only 10.18 - 10.21
35	3230 0028	Termostato Sicurezza	Safety Thermostat		1	
36	1229 0035	Guaina	Sheat	Ø6 L=800	1	
37	2416 0070	Protezione Termostato	Thermostat Cover		1	
38	3625 0095	Vite	Screw	4,2x13	2	
39	2807 0013	Rondella Speciale	Special Washer	Ø4,3x8x1,5	2	
40	3002 0662	Staffa Fissaggio Carena	Cover Braket		1	
41	1201 0090	Guarnizione Caldaia	Boiler Gasket	Ø10	1	
42	0009 0245	Corpo Inferiore	Bottom Body	Ø286x283 h100	1	
43	2822 0016	Refrattario	Refractory Pad		1	
44	3044 0016	Serpentina	Coil	11-15 l/min	1	6.15 - 8.15
	3044 0017	Serpentina	Coil	18-21 l/min	1	9.18 - 9.21 10.18 - 10.21
45	0604 0102	Dado	Bolt	M6	3	
46	2811 0097	Rondella	Washer	Ø6,5x18x1,5	3	
47	2811 0125	Rondella	Washer	Ø6,4x12x1,6	3	
48	3607 0243	Vite	Screw	M6x50	3	
49	0424 0375	Corpo Caldaia INOX	S. STEEL Boiler Body	11-15 l/min	1	6.15 - 8.15
	0424 0376	Corpo Caldaia INOX	S. STEEL Boiler Body	18-21 l/min	1	9.18 - 9.21 10.18 - 10.21
50	0402 0037	Coperchio	Cover	18-21 l/min	1	9.18 - 9.21
	0402 0215	Coperchio	Cover	11-15 l/min	1	3.11 - 5.15 6.15 - 8.15
51	0218 0010	Boccaglio	Air Nozzle		1	
52	0009 0163	Anello Boccaglio	Air Nozzle Ring		1	Solo / Only 6.15 - 8.15 9.18 - 9.21
53	0402 0131	Coperchio	Cover		1	
54	0600 0053	Dado Speciale	Special Bolt	M6	3	
55	2807 0024	Rondella Speciale	Special Washer	Ø6,4x11x2	3	
56	2815 0011	Rivetto	Rivet	3,8x12	3	
57	1201 0206	Guarnizione Camino	Chimney Gasket		1	
58	3002 0663	Staffa Fissaggio Carena	Cover Braket		1	

N°	Cod.	Descrizione	Description	Note	Q.ty	Model
59	2807 0013	Rondella Speciale	Special Washer	Ø4,3x8x1,5	2	
60	3625 0095	Vite	Screw	4,2x13	2	
61	3625 0049	Vite	Screw	3,5x9,5	1	
62	2811 0006	Rondella	Washer	Ø4,3x9	1	
63	0466 0026	Farfalla Aria	Fly Valve		1	
64	1810 0017	Manicotto	Sleeve		1	
65	1003 0063	Fascetta	Hose Clamp	368x4,8	2	
70	3208 1075	Tubo Gasolio in Rame	Copper Diesel Hose	11-15 l/min	1	6.15 - 8.15
	3208 1076	Tubo Gasolio in Rame	Copper Diesel Hose	18-21 l/min	1	9.18 - 9.21 10.18 - 10.21
71	0535 0073	Kit Cavi A.T.	H.T. Cable Kit		1	
72	0335 0029	Kit Bruciatore	Complete Burner Kit	1,50 - 80°AR-D	1	6.15 - 8.15 9.18 - 9.21
	0335 0032	Kit Bruciatore	Complete Burner Kit	2,00 - 60°H	1	10.18 - 10.21
73	3400 0576	Ugello Gasolio	Diesel Nozzle	1,50 - 60°B	1	6.15 - 8.15 9.18 - 9.21
	3400 0540	Ugello Gasolio	Diesel Nozzle	2,00 - 60°H	1	10.18 - 10.21
74	3608 0004	Vite	Screw	M3x6	3	
75	0602 0048	Disco Turbolenza Aria	Air Turbulence Ring	11-15 l/min	1	8.15
	0602 0050	Disco Turbolenza Aria	Air Turbulence Ring	18-21 l/min	1	6.15 - 9.18 9.21 - 10.18 10.21
76	3019 0035	Seeger Esterno	Outer Seeger	Ø22	1	
77	3200 0074	Tappo	Plug		1	
78	0602 0047	Disco Porta Elettrodi	Electrode Holder Disc		1	
79	2807 0013	Rondella Speciale	Special Washer	Ø4,3x8x1,5	3	
80	3625 0013	Vite	Screw	4,2x9,5	3	
81	2803 0322	Raccordo	Coupling	Ø4 GC1/8"	1	
82	0805 0032	Elettrodo Bifilare	Bifilar Electrode		1	
83	2819 0034	Rondella in Rame	Copper Washer	Ø5,3x11x0,5	1	
84	3623 0042	Vite	Screw	M5x16	1	
90	2815 0015	Rivetto	Rivet	3,4x7	3	
91	0218 0014	Boccaglio	Air Nozzle		1	Solo / Only 10.18 - 10.21
	0402 0359	Coperchio	Cover	18-21 l/min	1	

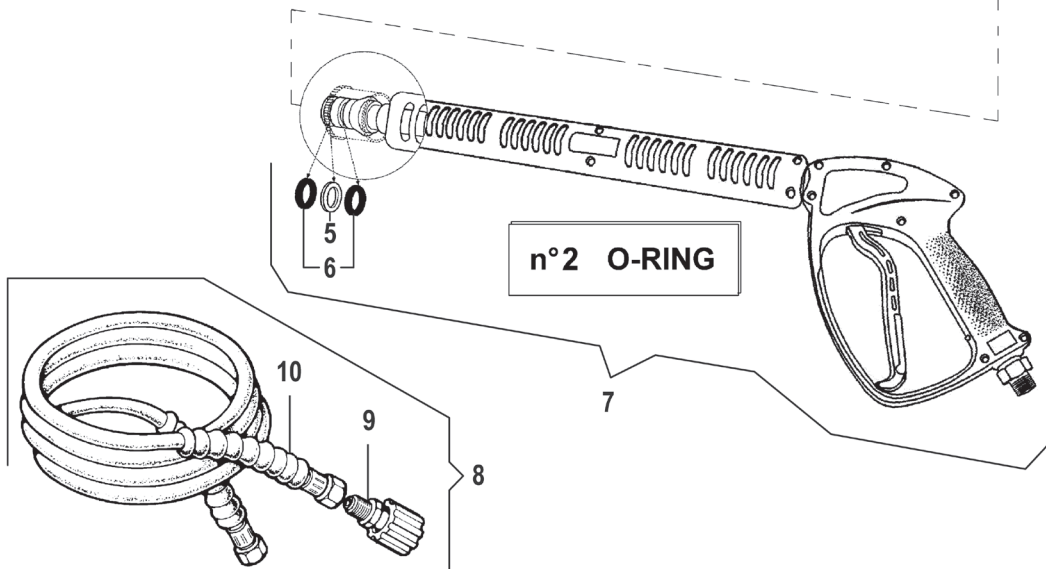
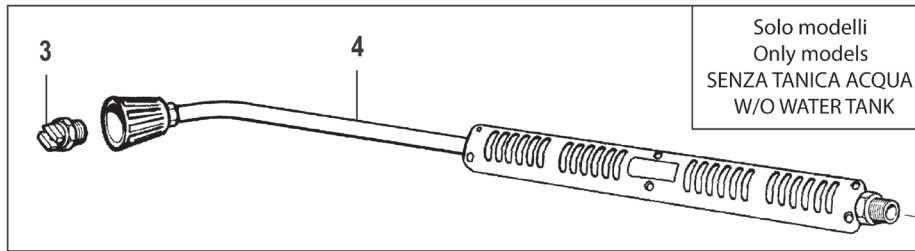
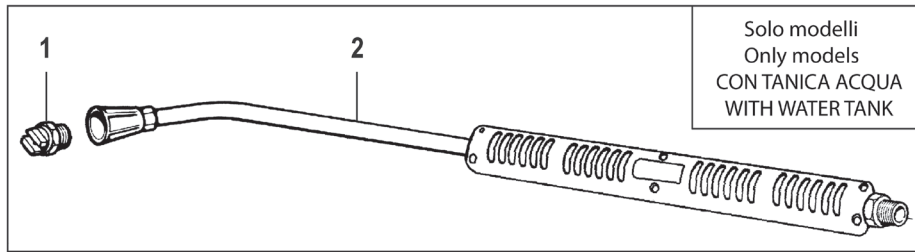

N°	Cod.	Descrizione	Description	Note	Q.ty	Model
1	3400 0707	Ugello Acqua	Water Nozzle	25 055 1/4" Meg (Blister COMET)	1	6.15
	3400 0705	Ugello Acqua	Water Nozzle	25 05 1/4" Meg (Blister COMET)	1	8.15
	3400 0708	Ugello Acqua	Water Nozzle	25 06 1/4" Meg (Blister COMET)	1	9.18
	3400 0711	Ugello Acqua	Water Nozzle	25 07 1/4" Meg (Blister COMET)	1	9.21
	3400 0746	Ugello Acqua	Water Nozzle	25 053 1/4" Meg (Blister COMET)	1	10.18
	3400 0710	Ugello Acqua	Water Nozzle	25 065 1/4" Meg (Blister COMET)	1	10.21
2	3301 0974	Kit Tubo Lancia	Lance Kit	L=760mm (Blister COMET)	1	
3	3400 0708	Ugello Acqua	Water Nozzle	25 06 1/4" Meg (Blister COMET)	1	6.15
	3400 0707	Ugello Acqua	Water Nozzle	25 055 1/4" Meg (Blister COMET)	1	8.15
4	3301 0976	Kit Tubo Lancia	Lance Kit	L=800mm (Blister COMET)	1	

N°	Cod.	Descrizione	Description	Note	Q.ty	Model
5	0009 0116	Anello BK	BK ring	Ø2,62x9,3	2	
6	1210 0084	Guarnizione OR Viton®	Viton® O-Ring	Ø2,62x9,13	2	
7	2410 0114	Pistola	Spray gun	n°2 O-rings (Blister COMET)	1	
8	3301 0987	Tubo Alta Pressione	H.P. Hose	R1 5/16" L=10m (Blister COMET)	1	6.15
	3301 0776	Tubo Alta Pressione	H.P. Hose	R2 5/16" L=10m (Blister COMET)	1	8.15
	3301 0944	Tubo Alta Pressione	H.P. Hose	R2 3/8" L=10m (Blister COMET)	1	9.18 - 9.21 10.18 - 10.21
9	1407 0027	Raccordo	Coupling	M22x1,5-G3/8	1	
10	3208 0743	Tubo Alta Pressione	H.P. Hose	R1 5/16" L=10m	1	6.15
	3208 0745	Tubo Alta Pressione	H.P. Hose	R2 5/16" L=10m	1	8.15
	3208 0919	Tubo Alta Pressione	H.P. Hose	R2 3/8" L=10m	1	9.18 - 9.21 10.18 - 10.21